

FACULTAD DE INGENIERÍA

Escuela Académico Profesional de Ingeniería Ambiental
Escuela Académico Profesional de Arquitectura

Tesis

**Project to Develop a Geothermal System to
Generate Electricity in Peru**

Lizbeth Eliana Torres Aquino
Elfry Patricia Vilcapoma Cordova
Enrique Paul Vilcapoma Cordova
Steve Dann Camargo Hinostroza

Para optar el Título Profesional de
Ingeniero Ambiental
Para optar el Título Profesional de Arquitecto

Huancayo, 2023

Repositorio Institucional Continental
Tesis



Esta obra está bajo una Licencia "Creative Commons Atribución 4.0 Internacional" .

INFORME DE CONFORMIDAD DE ORIGINALIDAD DE TESIS: EN FORMATO
ARTÍCULO CIENTÍFICO

A : FELIPE NESTOR GUTARRA MEZA
Decano de la Facultad de Ingeniería

DE :
STEVE DANN CAMARGO HINOSTROZA
Asesor de tesis

ASUNTO : Remito resultado de evaluación de originalidad de tesis

FECHA : 25 de Julio de 2023

Con sumo agrado me dirijo a vuestro despacho para saludarlo y en vista de haber sido designado asesor de la tesis titulada: "PROJECT TO DEVELOP A GEOTHERMAL SYSTEM TO GENERATE ELECTRICITY IN PERU", perteneciente al/la/los/las estudiante(s) ELFRY PATRICIA VILCAPOMA CORDOVA, de la E.A.P. de Ingeniería Ambiental LIZBETH ELIANA TORRES AQUINO, de la E.A.P. de Ingeniería Ambiental, ENRIQUE PAUL VILCAPOMA CORDOVA, de la E.A.P. de Arquitectura; se procedió con la carga del documento a la plataforma "Turnitin" y se realizó la verificación completa de las coincidencias resaltadas por el software dando por resultado 16 % de similitud (informe adjunto) sin encontrarse hallazgos relacionados a plagio. Se utilizaron los siguientes filtros:

- Filtro de exclusión de bibliografía SI NO
- Filtro de exclusión de grupos de palabras menores (Nº de palabras excluidas: 5) SI NO
- Exclusión de fuente por trabajo anterior del mismo estudiante SI NO

En consecuencia, se determina que la tesis constituye un documento original al presentar similitud de otros autores (citas) por debajo del porcentaje establecido por la Universidad.

Recae toda responsabilidad del contenido la tesis sobre el autor y asesor, en concordancia a los principios de legalidad, presunción de veracidad y simplicidad, expresados en el Reglamento del Registro Nacional de Trabajos de Investigación para optar grados académicos y títulos profesionales – RENATI y en la Directiva 003-2016-R/UC.

Esperando la atención a la presente, me despido sin otro particular y sea propicia la ocasión para renovar las muestras de mi especial consideración.

Atentamente,



Asesor de tesis

DECLARACIÓN JURADA DE AUTORÍA

El presente documento tiene por finalidad declarar adecuada y explícitamente el aporte de cada estudiante en la elaboración del artículo de investigación a ser utilizado para la sustentación de tesis: formato de artículo científico.

Yo: ELFRY PATRICIA VILCAPOMA CORDOVA, con Documento nacional de identidad (DNI) N° 74049504; teléfono 992116933; estudiante de la Escuela Académico Profesional de Ingeniería Ambiental.

Yo: LIZBETH ELIANA TORRES AQUINO, con Documento nacional de identidad (DNI) N° 74980985; teléfono 933272445; estudiante de la Escuela Académico Profesional de Ingeniería Ambiental.

Yo: ENRIQUE PAUL VILCAPOMA CORDOVA, con Documento nacional de identidad (DNI) N° 74049309; teléfono 991196262; estudiante de la Escuela Académico Profesional de Arquitectura.

Yo: STEVE DANN CAMARGO HINOSTROZA, con Documento nacional de identidad (DNI) N° 43979868; teléfono 998998506; Docente de la Escuela Académico Profesional de Ingeniería Ambiental.

Ante Usted, con el debido respeto me presento y expongo:

Declaramos que hemos participado en la ideación del problema, recolección de datos, elaboración y aprobación final del artículo científico.



Nombre: Elfy Patricia Vilcapoma Cordova

Fecha:

DNI: 74049504

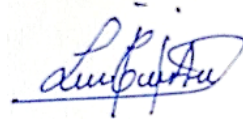

Nombre: Lizbeth Eliana Torres Aquino

Fecha:

DNI: 74980985



Nombre: Enrique Paul Vilcapoma Cordova

Fecha:

DNI: 74049309



Nombre: Steve Dann Camargo
Hinojosa

Fecha:

DNI: 43979868



V.B. del asesor designado

Project to Develop a Geothermal System to Generate Electricity in Peru

ORIGINALITY REPORT

16%	14%	3%	0%
SIMILARITY INDEX	INTERNET SOURCES	PUBLICATIONS	STUDENT PAPERS

PRIMARY SOURCES

1	openjicareport.jica.go.jp Internet Source	7%
2	www.journaltoocs.ac.uk Internet Source	3%
3	www.researchgate.net Internet Source	2%
4	www.thinkgeoenergy.com Internet Source	1%
5	Submitted to Infile Student Paper	<1%
6	Leite, André Luís, Antonio Carlos Figueiredo Pinto, and Marcelo Cabus Klotzle. "Effects of Idiosyncratic Volatility in Asset Pricing", Revista Contabilidade & Finanças, 2016. Publication	<1%
7	Yichun Gong, Ruilian Zhang, Kaiwen Yao, Bingwen Liu, Feilong Wang. "A Livelihood Resilience Measurement Framework for Dam-	<1%

Induced Displacement and Resettlement", Water, 2020

Publication

- | | | |
|----|---|------|
| 8 | M. Balat, H. Balat, U. Faiz. "Utilization of Geothermal Energy for Sustainable Global Development", Energy Sources, Part B: Economics, Planning, and Policy, 2009
Publication | <1 % |
| 9 | Sandra Cueto, Jorge Ferrer, Alvaro Guevara, Yensy Segovia. "Analysis of the Socio-environmental Management of Covid 19 in Perú", E3S Web of Conferences, 2021
Publication | <1 % |
| 10 | Alejandro García Gil, Eduardo Antonio Garrido Schneider, Miguel Mejías Moreno, Juan Carlos Santamarta Cerezal. "Shallow Geothermal Energy", Springer Science and Business Media LLC, 2022
Publication | <1 % |
| 11 | Ghaffour, Noredine, Jochen Bundschuh, Hacene Mahmoudi, and Mattheus F.A. Goosen. "Renewable energy-driven desalination technologies: A comprehensive review on challenges and potential applications of integrated systems", Desalination, 2015.
Publication | <1 % |
-

12	<p>Pedro Angumba, Andres Cardenas, Daniel Icaza. "Geothermal and Solar Energy Applied to Air Conditioning and Electricity Generation for Homes: Case study Baños in Cuenca-Ecuador", 2022 10th International Conference on Smart Grid (icSmartGrid), 2022</p> <p>Publication</p>	<1 %
13	<p>Ronald Alexander Aguilar Leonardo. "Evaluation of the reduction of seismic loads effect in tall buildings through their geometric configuration in plan", Journal of Physics: Conference Series, 2022</p> <p>Publication</p>	<1 %
14	<p>ri.itba.edu.ar</p> <p>Internet Source</p>	<1 %
15	<p>www.copernico.eu</p> <p>Internet Source</p>	<1 %
16	<p>P. Moya Rojas. "Central and South America", Elsevier BV, 2016</p> <p>Publication</p>	<1 %

Exclude quotes On
Exclude bibliography On

Exclude matches < 5 words

Project to Develop a Geothermal System to Generate Electricity in Peru

Elfry Vilcapoma Córdova^{1,*}, Lizbeth Torres Aquino¹, Enrique Vilcapoma Córdova², Steve Camargo Hinostroza¹

¹Professional Academic School of Environmental Engineering. Faculty of Engineering. Continental University, Huancayo, Peru.

²Professional Academic School of Architecture. Faculty of Engineering. Continental University, Huancayo, Peru.

*Email: 74049504@continental.edu.pe

Abstract.

The use of renewable energy has been very important in recent decades for conserving nature, conserving its natural resources, and reducing environmental impacts. According to the ONU in 2019, greenhouse gases increased from 123% to 147% in the atmosphere, so one of the best alternatives that will help preserve our nature is geothermal energy, helping not only to take care of the environment but also to generate electricity, since in several countries the main problem is the lack of electricity, because it is essential for our daily tasks. This article presents it as a natural resource of our ecosystem that must be used to the maximum for electricity generation. For this, we will announce the most suitable places, for an optimal design. It will show different places in Peru that have the features, where you can implement a geothermal system. Tacna is the most relevant place with a lot of geothermal energy, and this was the place chosen for the geothermal system. It is therefore essential to exploit energy that is not exhausted, thereby increasing the use of new clean energy sources.

Keywords: Geothermal energy, Environmental impact, and Electric power.

JEL Classifications: Environment, Renewable Resources and Conservation.

Received: 28/07/2022 Accepted: 21/10/2022 DOI: <https://doi.org/10.32479/ijeep.13534>

1. Introduction

The new alternatives offer a solution to the problem of the lack of electricity, such as geothermal energy (Sera, 2015). The global landscape of geothermal energy has the concept that it is a heat pump, in 76 countries of the world have the basic resources to enjoy this energy, which brings savings of approximately 300 million barrels of oil (Sanchez et al., 2011).

Geothermal energy is very beneficial because it takes advantage of the heat that radiates from the center of the earth, we can also define it as quantifiable energy (Gil, 2019). This clean alternative is not only environmentally positive but also viable in the field of the economy and is favored in the energy matrix of each country, it is also self-sufficient in the high costs of energy materials (Brunl, 2014).

In the unique case of the power generation plant from geothermal energy, it has several advantages, among them: independence, relatively inexhaustible, emits the least pollution emission, does not depend on the hydrocarbon market, and contributes to the development of areas remote (Vega, 2013). If we talk about geothermal power plant designs, we need the heat reservoir, reservoir, and fluid, these elements are the most essential for the formation of a system, it also involves the enthalpy of the heat source, according to this is taken from the appropriate design, the value of this fluctuates between 150 to 225 ° C approximately (Dickson & Fanelli, 2004).

In Peru, it is desired that this primary resource be developed in the best possible way for the generation of electricity, as well as other purposes of the use of heat. (Pulido, 2017) It must begin with an expedition that will be developed in medium to long-term terms in the energy diversification strategy (Bjork et al., 2014).

This energy has not yet been studied in Peru, but there are some studies in Latin America, for the Inter-American Development Bank, this energy is important for which measures have been taken for the process of these investigations, in the last 3 years the Senior management created the Special Group for Mining, Geothermal, and Hydrocarbons, where projects on geothermal energy have been developed and supervised among 15 Latin American countries (OSINERGMIN, 2016).

The problems identified are related to the adequate design for the generation of electrical energy, for which an analysis of the Peruvian territory is needed to consider the possible areas where a large amount of heat is found. (Supervisory Agency for Investment in Energy and Mining - OSINERGMIN, 2017) Volcanoes, geysers, and hot springs are considered the main sources that can be used as geothermal energy, and to be exploited and generate electricity, the types are taken into account. of geometric designs appropriate to the amount of temperature and territorial area. (Pous & Jutglar, 2004)

In our work we intend to propose the proper design of a geothermal system to generate electricity, considering the geothermal areas of Peru. This research provides us with new technological knowledge for a later project to implement this system because this research is technological, and this would also generate benefits for the closest population.

2. Theoretical Framework

Peru has always been supplied throughout its territory with hydroelectric, natural gas, and thermal sources, this makes it diverse in terms of electrical energy, and this also leads to problems with these same sources for their production and generation in the future. For this reason, geothermal energy allows options to be part of these energy pillars, this energy is clean, renewable, and sustainable (Figueroa, 2015). Our country is covered with resources and geothermal materials that can be used, which average between 2,500 and 3,000 MW, making it clear that Peru is one of the Latin American countries with geothermal energy possibilities (Adams et al., 2021). Some companies take advantage of the energy for the last 10 years together with the support of the Peruvian government, in 2012 a geothermal energy plan was launched, To be better known in the Peruvian energy industry, this plan is still being continued so that this sustainable and environmental option is notable. It is expected that in the following years geothermal energy will be one of the most sought-after alternatives, although this is seen affected by the difficulties on the part of the population and the regulations of our country, as well as with the design of infrastructure and its management, added to this is the lack of interest in the studies of this subject (Munoz et al., 2014).

Also, in the Organic Law of Geothermal Resources - Law No.26848 that was promulgated in July 1997 and April 2010 its respective regulations were approved. This law and its regulations are part of the framework for the promotion of geothermal development in the private sector. In 2012, the holders of authorizations paid a small amount established in article 62 of SUPREME DECREE 019-2010-EM.(The Republic of Peru, 1997) In addition, according to Article 17, it is stipulated that if the holders of the authorization do not carry out their established activities the guarantee of 5% of the budget for phase II of the exploration period shall be forfeited. Unlike phase I of the exploration period, there is no penalty, even if the authorization holders do not comply with the programmed activities (Palacio-Villa et al., 2020). Therefore, when incumbents consider not viable from the economic sector, they may consider studying the fields, but still having geothermal rights, for this purpose, the MEM has the function of supervising the scanning tasks in case they are being developed or not (Lorente, 2020).

According to Franklin Acevedo, manager of the company specializing in geothermal energy EDC Peru "Peru has a geothermal potential of more than 3,000 MW, which is equivalent to 50% of the electricity produced today throughout the country, thanks to our strategic location on the Belt of Fire of the Pacific".(Acevedo, 2020) Brings with it different benefits to several Peruvians such as:

- Ensures sustainable supply, since geothermal energy is clean energy, since it is generated in a closed cycle and sustainable in production
- A geothermal reservoir can be inexhaustible if it is managed efficiently.

- The heat of the earth is 24 hours a day, so the supply of electricity is guaranteed 365 days a year.
- Increase the productivity of renewable energies throughout the country.
- Alternative to saving fuel and natural gas.
- Contribute to the supply of electricity in Peru.
- Elimination of greenhouse gases, produced in thermal plants.
- Generation of jobs throughout the project and production.

In the research study of Laguna Monroy in 2012, it was sought to increase the development and research of the different alternative energies and with them to be able to gradually reduce the dependence that exists in the companies with fossil fuels in the medium term of the federal district of Mexico, for these 3 well-known methods were carried out: NOx only from solar turbines, Rolls-Royce dry low emissions and the dry low NOx process. For the analysis, different plants of different designs had to be evaluated, each one in the same period to see which method is the most indicated in this investigation, reaching the result that the flash cycle plant has a great energy efficiency unlike the other two methodologies, It also has operational reliability and low emission levels along with minimum costs, this shows us that it can help the environment and take care of the country's economy, so its construction is much faster and also favors its use in the current reform process of the electricity sector in Mexico (Lagoon, 2002).

According to Eduardo Parancan, geothermal energy has different advantages for being a renewable energy source since unlike other energies it gives us significant benefits such as:

- Environment friendly.
- Reliable energy Indigenous energy.
- To a certain extent, economically viable.
- Multiple uses of heat (Eduardo et al., 2016).

2.1. TÍPOS DE GEOTERMAL FIELDS

High-temperature deposits: They are found at more than 150 °C, mainly in areas with a very high geothermal gradient of up to 30 °C per 100 m. These always coincide with geological phenomena since in this place there are volcanoes and geysers, they are produced by the movements of the masses of molten rocks that we mostly know as magma and by the displacement of the lithospheric plates, these usually move very slowly at year between 1 to 20 cm, and it is in these areas where the magma can escape and rise, starting the volcanoes. Most high-temperature deposits have three basic geological conditions: heat source; aquifers and impermeable layer (BULNES JIMENEZ, 2018).

Medium temperature deposits: They are found between 90 to 150 °C at depths between 2,000 and 4,000 m, mainly in areas considered lithospheric thinning, these areas have a high concentration of radioactive isotopes. (Navarra, 2018) These deposits are found mainly in points with water sources that they can easily return to the surfaces, we can see them in the hot springs. Like high-temperature deposits, they have a magmatic intrusion from an aquifer as their heat source, but they do not have intermediate layers (Garcia de la Noceda, 2008).

Low-temperature deposits: They are found mostly between 30 and 90 °C, mainly in sedimentary basins, and have a depth that is considered adequate between 1,500 and 2,500 m. The fluids circulate easily, in addition to not containing a large amount of heat, so they can be extracted. The geological gradient must be normal since it will be between 3 °C every 100 m and at an approximate depth of 2000 m, the temperature of these gradients can reach up to 70 °C or more (Llopis & Rodrigo, 2008).

Very low-temperature deposits: They are found practically in the earth's crust at a temperature of 30 °C or less. These deposits are always interrupted by large masses of water, whether continental or marine. This energy is mainly used for individual homes or buildings with geothermal heat pumps. At the ground surface the heat changes constantly with temperature variations, this can be observed down to a depth of 0.5 m. A depth of 10 m is where the subsoil can store heat, at a depth of 15 m the temperature will be constant throughout the year, but rarely this temperature can vary, and at a depth of 20 m the temperature increases 3 °C every 100 m. (Gudni, 2004).

2.2. EXPLOTATION TECHNOLOGIES

Geothermal resources of the high, medium, or low thermal magnitude determine their possibilities of use, depending on the technology available at any given time. However, there are two main types of applications or purposes:

- Resources of high and medium thermal magnitude or enthalpy.
- Resources of low and very low thermal magnitude or enthalpy.

The technologies worked on in each situation change depending on the resource model used, its interior, and the use to be made available, for which we have the following resources:

Dry steam resource: It is the known dominant vapor system, those that have no liquid phase or are very rare. The geyser in California and La Darello in Italy are examples of high-temperature hydrothermal systems, where the rocks are more saturated by liquid vapor. This system does not need steam, it must be separated from the water and they are the least frequent (Rivera Delgado et al., 2021).

Wet Steam Resource: This is for high thermal magnitudes, related to hydrothermal water systems at high temperatures, to generate steam that can be used firsthand for electricity. In these systems, the flow is liquid which then changes to vapor (Rivera Delgado et al., 2021).

Moderate enthalpy resources: They are systems that generate fluids that are not transformed into a solution of steam and liquid, but despite these difficulties, this system is not enough to produce enough steam for their exploitation (Brender, 2018).

2.3. TYPES OF PLANTS FOR ENERGY PRODUCTION

Dry steam plant: These plants are in operation to provide more services. It has a 100-year history, and longer than any other dry steam geothermal resource technology, the fluid reaches the surface and cracks the ground. In a saturated or slightly superheated state (dry steam), it goes directly into the power generation of the turbines (Fernández Menéndez et al., 2020).

Flash plant: It is suitable for the use of energy with high energy values since it deals with the mixture of water vapor and salt, it is usually used when the temperature value ranges between 180 to 240 °C. The liquid that reaches the top is a combination of vapor-liquid at a directly proportional pressure of the well and the level of temperature congestion, so it is necessary to separate both stages, for this process it must be treated by separators and using a turbine gives us electrical energy. (Valenzuela Fuentes & Valenzuela Fuentes, 2011)

Binary cycle plant: The binary cycle plant aims to extract energy from different medium temperature deposits, in a range of 100 and 150 °C, and from geothermal resources with high salinity. This plant is based on avoiding the direct use of thermal fluid since it mainly uses a secondary fluid. When the geothermal fluid has an enthalpy greater than 200 kcal/kg, water can be used as secondary fluid, but if it has a lower enthalpy, it is considered a medium temperature reservoir, in which it will be used as a secondary fluid that has a better thermodynamic behavior, this refers to a low boiling point and high vapor pressure at high temperatures (de Almeida Tonus et al., 2022).

3. Results

To make a geothermal system, you must choose the right place where there are geothermal reservoirs that meet geophysical and geological conditions, so that your resource can be used. Around the world, different thermal energy sources are already being used, such as in Italy, New Zealand, and the United States.

Figure 1. Geothermal energy (Paucara, 2012)

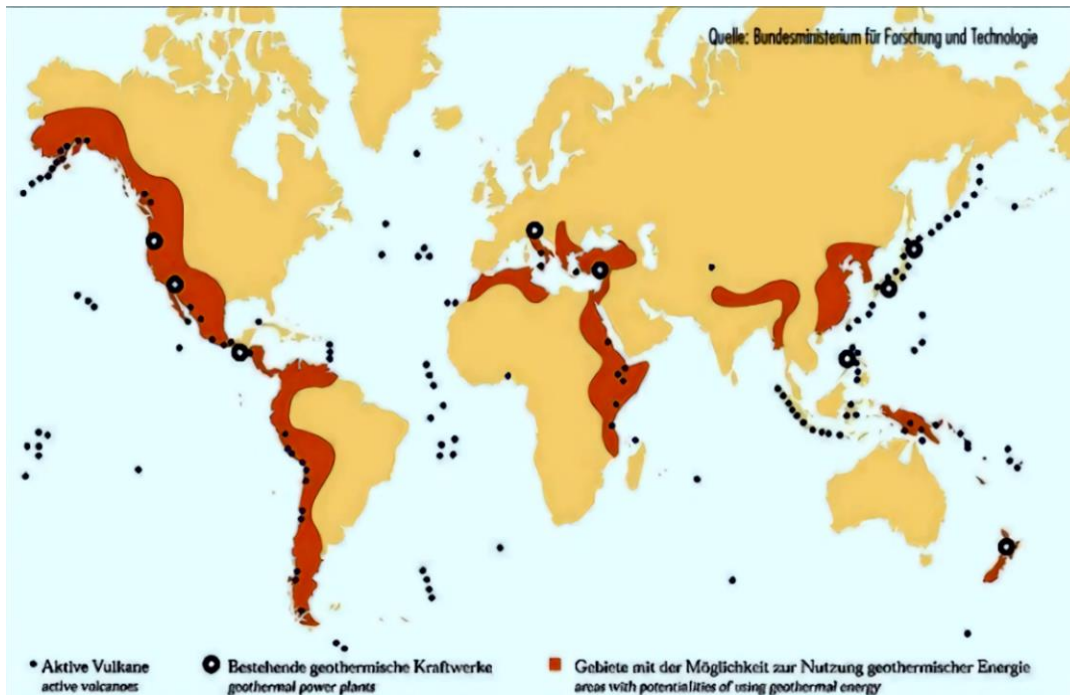

Source: Sources with the largest geothermal energy worldwide.

At the national level, geothermal energy sources are found mainly in the center and south of Peru. Where we can see that the area with potential for geothermal energy is in the south, with Tacna being the region with the most geothermal potential in the entire country.

Figure II. Map of geothermal regions of Peru Perú (INGEMMET, 2018)

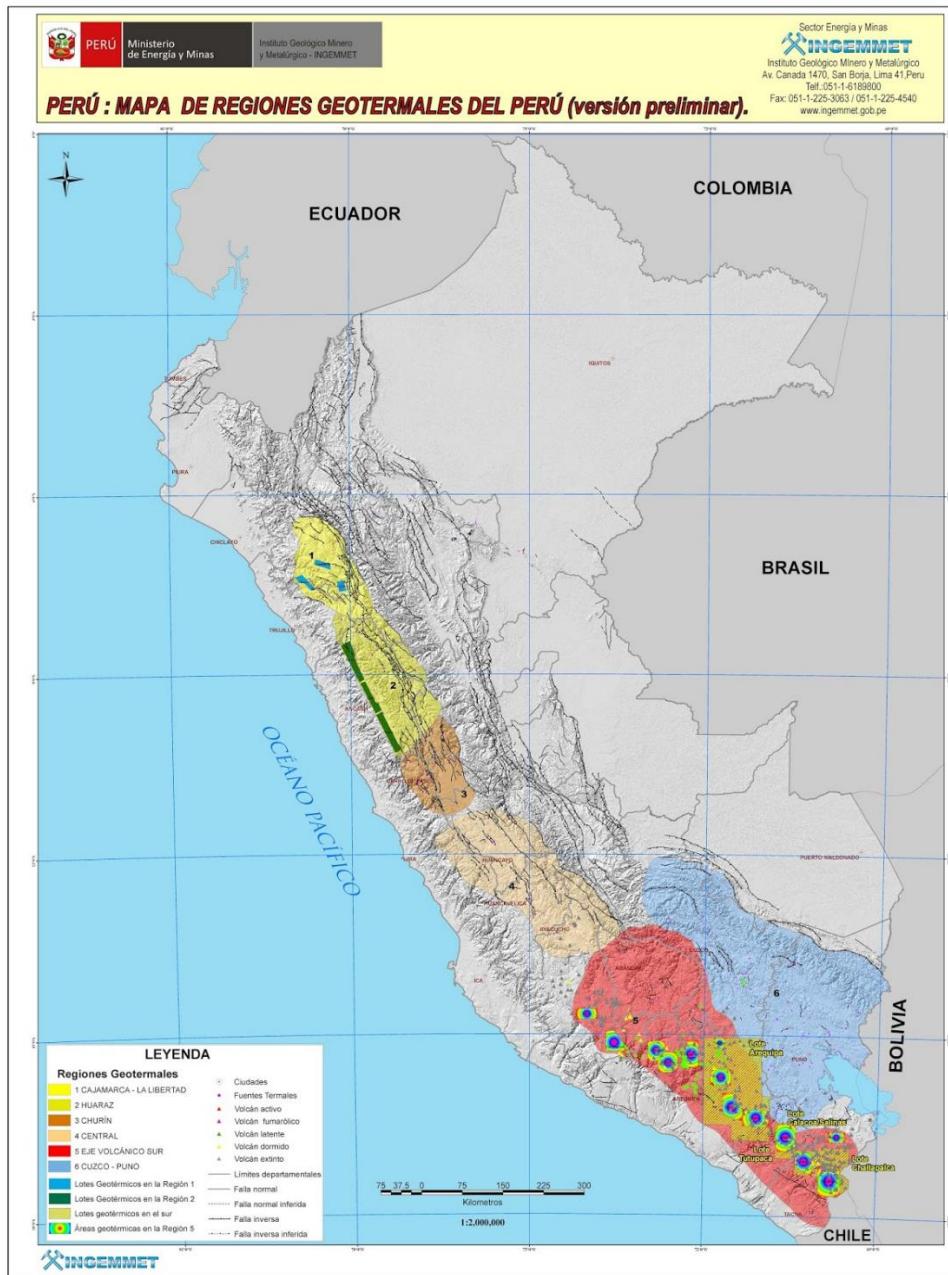

Source: Sources with greater geothermal energy at the national level.

Figure III. Map of geothermal departments (Pauccara et al., 2021)

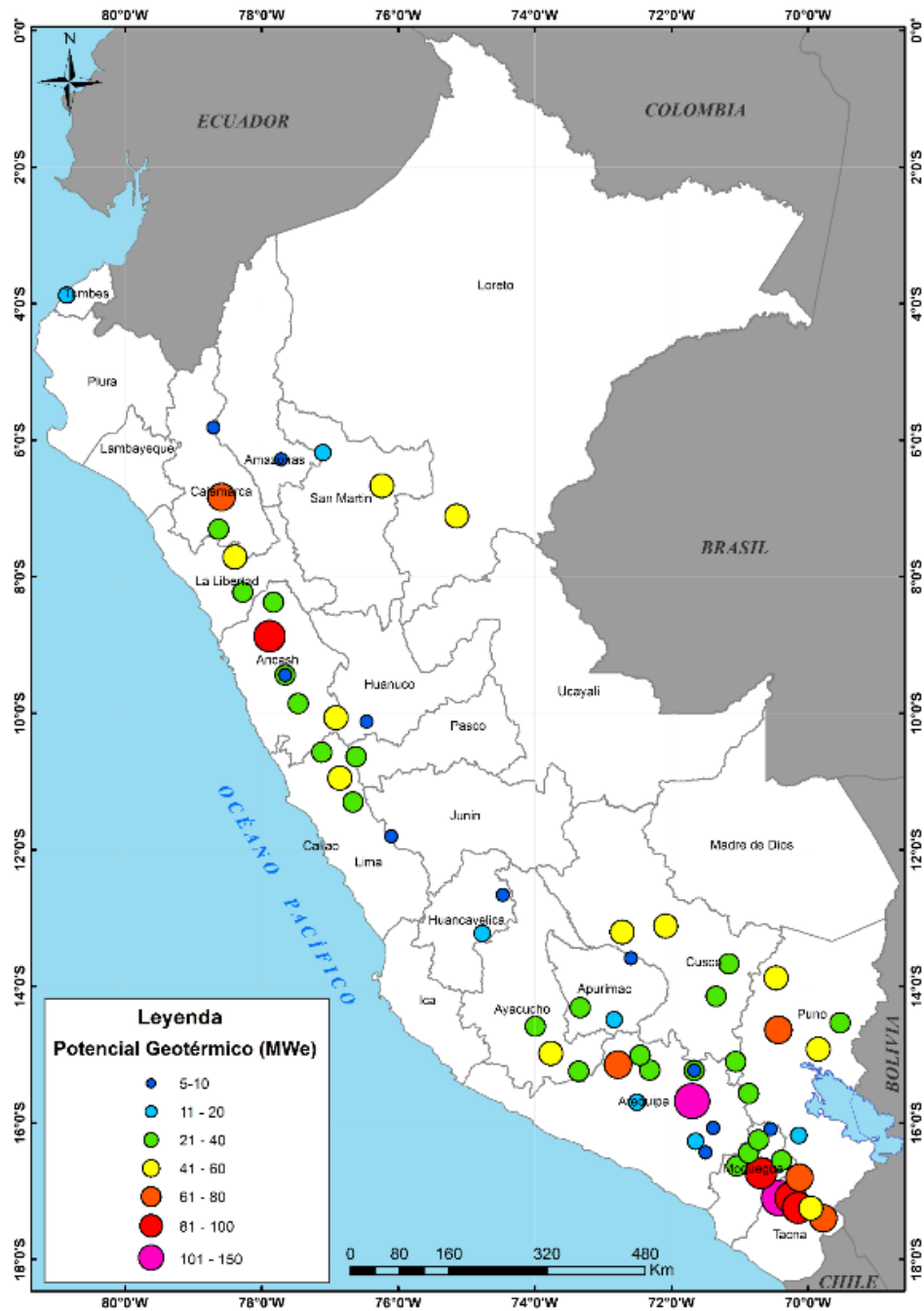

Source: Sources with greater geothermal energy at the departmental level.

For energy development, 61 fields were evaluated throughout the Peruvian territory, where the temperature of hot water and the chemical composition was analyzed, for this the potential of the resources, the relationship with protected areas, and the concession of resources are shown in the following table. exploration rights.

Table I. Summary of the geothermal potential of Peru for electricity generation.

Geothermal Region	NO.	Region	Field Name	Resource Potential (MWe)		No. of Sectors
				Promising Fields	Other fields	
Northern Peru	1	Tumbes	Tumbes		15	2
	2	Amazon	El Almendral		10	2
	3	San Martin	Pirurohuasi		58	6
	4	Loretto	Contamana		48	3
Cajamarca - Liberty	5	Cajamarca	Quilcate		70	7
	6	Cajamarca- Freedom	Huaranchal		54	5
Huaylas Alley	7	Ancash- The Freedom	Tablachaca		29	5
	8	Ancash	Chancos	15.3	21	3
	9	Huanuco- Ancash	Azulmina		53	5
Churin	10	Lime	Conoc		21	3
	11	Pasco	Tambochaca		24	2
	12	Lime	Oyon		45	5
Center	13	June	Yauli		7	1
	14	Huancavelica	Coris		10	1
Volcanic Axis	15	Cuzco- Apurimac	Cconoc		9	2
	16	Apurimac	Pincahuacho		25	2
	17	Ayacucho	Puquio	34.3	10	1
	18	Arequipa	Cailloma	9.1	26	2

	19	Arequipa	Chivay	162.9	136	9
	20	Moquegua	Calacoa-Putina	108.2	45	4
	21	Moquegua	Ccollo/Titire	39.7	27	3
	22	Moquegua- Tacna	Crucero	79.4	3	1
	23	Tacna	Tutupaca	113.8	29	5
	24	Tacna	Calientes	100	0	0
	25	Tacna	Ancocollo	98.2	55	4
	6	Tacna	Borateras	40	31	3
	27	Tacna	Chungara-Kallapuma	84	17	3
Cusco-Puno	28	Cuzco	Machu-Picchu		49	6
	29	Puno	Pasanocollo		65	6
	30	Puno	Pinaya	36.8	27	2
	31	Moquegua	Jesus Maria	17.3	17	2
TOTAL				939	1036	105
GRAND TOTAL				1975		

Source: The authors synthesis from Vega, 2013

Table II. Summary of classification by priorities for the development of geothermal fields in Peru

Region	Field Name	hot springs	Potential (MWe)			Possible Capacity to Develop (MWe)	Protected area	development importance
			Promising Fields	Other Fields	Total			
Ancash	Chancos	72	15,3	21	36,3	5		D-1
Ayacucho	Puquio	80	34,3	10	44,3	30		A
Arequipa	Cailloma	58	9,1	26	35,1	5		C
	Chivay - Pinchollo	93	172,9	136	308,9	150		B
Moquegua	Ulucan	80	27,4	0	27,4	25		B
	Calacoa-Putina	91	108,2	45	153,2	100		A
	Collo/Titire	83	39,7	27	66,7	35		B
	Jesus Maria	52	17,3	17	34,3	10		D-1
Moquegua - Tacna	Crucero	73	79,4	3	82,4	70		-
Tacna	Tutupaca	86	113,8	29	142,8	105		A
	Calientes	90	100	0	100	100	Regional conservation area	-
	Ancocollo	87	98,2	55	153,2	90	Regional conservation area	B
	Borateras	87	40	31	71	50	Regional conservation area	-
	Chungara - Kallapuma	85	84	17	101	75	Historic sanctuary	-
Puno	Pinaya	83	36,8	27	63,8	35		A

Source: The authors synthesis from Vega, 2013.

Table III. Qualification and evaluation criteria for prioritization in development

Priority	Description	Resource Potential	Exploration Authorization	Topography and Access	Protected areas
Priority A	A short time development is expected (developments would be even without government support)	High geothermal potential expected	Approved	There is no major problem	Does not exist
Priority B	Next in importance to those of priority A (only authorization for exploration is expected)		It has been applied but not yet approved		Does not exist (to be confirmed)
Priority C	Development is expected more or less in the short term, but the potential of the resource is yet to be confirmed.	High resource potential is anticipated	Approved	Detail topography is required	Does not exist (need to confirm for some fields)
Priority D-1	The potential of the resource is yet to be confirmed (however, based on existing information, a high potential is expected)		not approved		
Priority D-2	The potential of the resource is yet to be confirmed (however, based on existing information, a high potential awaits us)	It is not possible to evaluate the potential of the resource			
Others	The environmental impact of these projects must be carefully evaluated. If the impact can be avoided or adequately mitigated, geothermal development should be allowed.	-	-	-	Existence of protected areas

Source: The authors synthesis from Vega, 2013.

For the evaluation of priorities, the development plans applied to potential fields previously selected by the master plan were observed in detail.

- Plans for the Development of Promising Fields: 13 geothermal fields with high potential were chosen and investigated under various conditions for energy development. The development scale and specifications for energy development are displayed in the following table.

Table IV. Main specifications for the possible development of electricity generation in geothermal fields

Field Name	Resource Potential P80 (MWe)	Possible development capacity (MWe)	Units	Numbers of production wells	Numbers of reinjection wells
Chungara-Kallapuma	84	75	25MW x 3	19	9
Ancocollo	98,2	90	30MW x 3	18	9
Tutupaca	113,8	105	35MW x 3	15	9
Crucero	79,4	70	35MW x 2	13	7
Pinaya	36,8	35	35MW x 1	13	6
Calacoa-Putina	108,2	100	25MW x 4	25	13
Ulucan	27,4	25	25MW x 1	5	4
Jesus Maria	17,3	10	10MW x 1	7	3
Ccollo/Titire	39,7	35	35MW x 1	10	5
Cailloma	9,1	5	5MW x 1	5	2
Chivay-Pinchollo	162,9	150	25MW x 6	22	13
Puquio	34,3	30	30MW x 1	12	5
Chancos	15,3	5	5MW x 1	5	2
TOTAL	826,4	735	-	-	-

Source: The authors synthesis from Vega, 2013.

According to table N°5, the priority is where the 5 chosen fields are located where the exploitation right authorization is granted.

Tabla V: Resultado del desarrollo de evaluación de prioridades. (Vega, 2013)

Priority	Description	geothermal field	Possible Power (Mw)	Total (Mw)
Priority A	A short time development is expected (developments would be even without government support)	Tutupaca	105	340
		Crucero	70	
		Calacoa-Putina	100	
		Pinaya	35	
		Puquio	30	
Priority B	Next in importance to those of priority A (only authorization for exploration is expected)	Chivay Pinchollo	150	300
		Ancocollo	90	
		Ccollo/Titire	35	
		Ulucan	25	
Priority C	Development is expected more or less in the short term, but the potential of the resource is yet to be confirmed.	Cailloma	5	(60)
		Huancarhuas	(30)	
		Paila del Diablo	(15)	
		Pararca	(10)	
Priority D-1	The potential of the resource is yet to be confirmed (however, based on existing information, a high potential is expected)	17 courses (including Chancos and Jesus Maria)	-	Unknown
Priority D-2	The potential of the resource is yet to be confirmed (however, based on existing information, a high potential awaits us)	24 fields	-	Unknown
Others	The environmental impact of these projects must be carefully evaluated. If the impact can be avoided or adequately mitigated, geothermal development should be allowed.	7 courses (including Borateras, Calientes and Chungara-Kallapuma)	-	Unknown

Source: Master Plan for the development of geothermal energy in Peru.

According to the geothermal energy master plan carried out by INGEMMET, the Tacna region has five main sources with great geothermal potential, which are: Tutupaca, Calientes, Ancocollo, Chungará-Kallapuma and Borateras.

Figure IV. Geothermal map of the department of Tacna (INGEMMET, 2018)

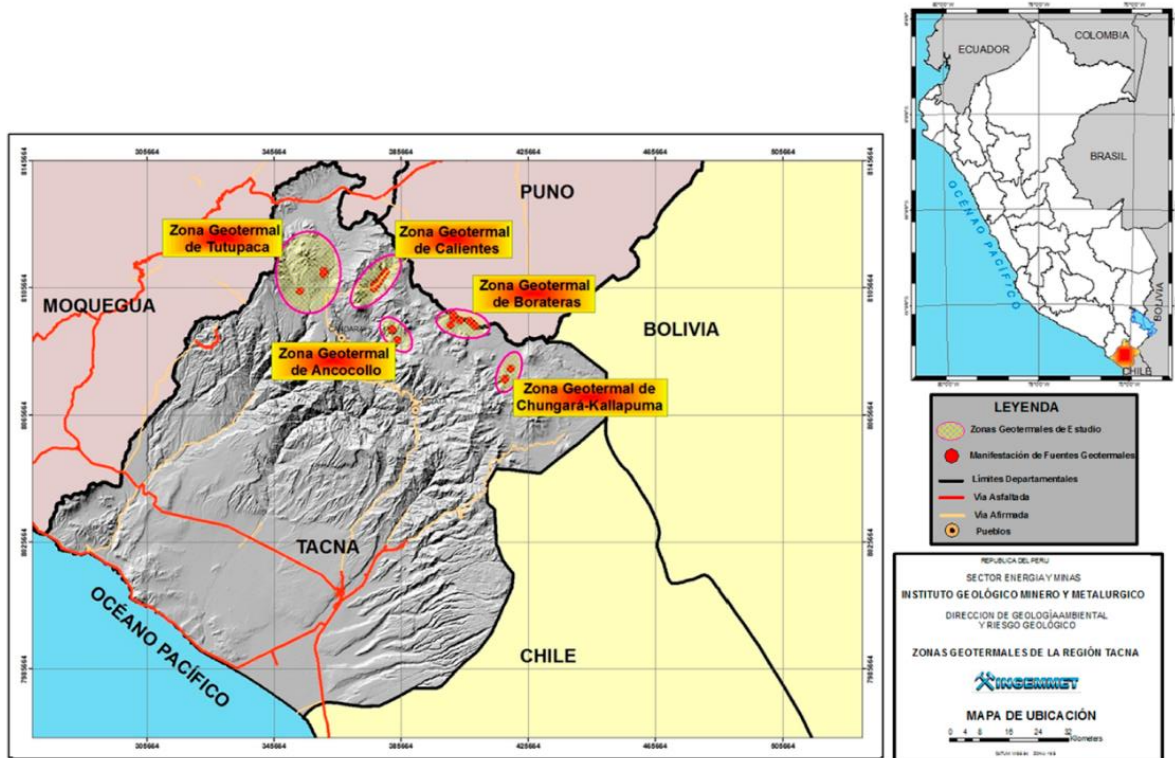

Source: Specific places with the greatest source of geothermal energy in the department of Tacna.

According to the INGEMMET map, the areas of Calientes, Borateras, and Chungara have a high geothermal temperature (above 240 °C), and that is why it is not considered geothermal system, unlike the areas of Tutupaca and Ancocollo, which they are found in the appropriate temperature ranges for the generation of electrical energy (180-240°C).

The area with the greatest geothermal potential to be developed is Tutupaca since this area can reach 105 MWe, unlike other areas such as Ancocollo with an energy potential of 90 MWe. Therefore, the appropriate place for the geothermal system in Peru is the area of Tutupaca in the department of Tacna, this is evaluated by the geothermal temperature and the energy potential to be reached.

The geothermal area of Tutupaca is located in the western Andes mountain range in the department of Tacna, between 4,000 and 4,500 meters above sea level. The Tutupaca volcano is located in this area and is surrounded by the east by the Callazas River and to the west by the

Tacalaya River. It is located in a high Andean zone, for which its climate is cold, and rocky terrain with scarce flora predominates.

In Tutupaca, 36 geothermal manifestations were inventoried, where three main sectors stand out: La Pampa de Turun Turun; the Tacalaya river and the Azufre Grande and Azufre Chico streams. According to Fournier's silica-enthalpy diagram (1977), different temperatures were calculated in the Tutupaca area, reaching 233°C.

Figure V. Hydro geochemical model of the Tutupaca geothermal zone (INGEMMET, 2014).

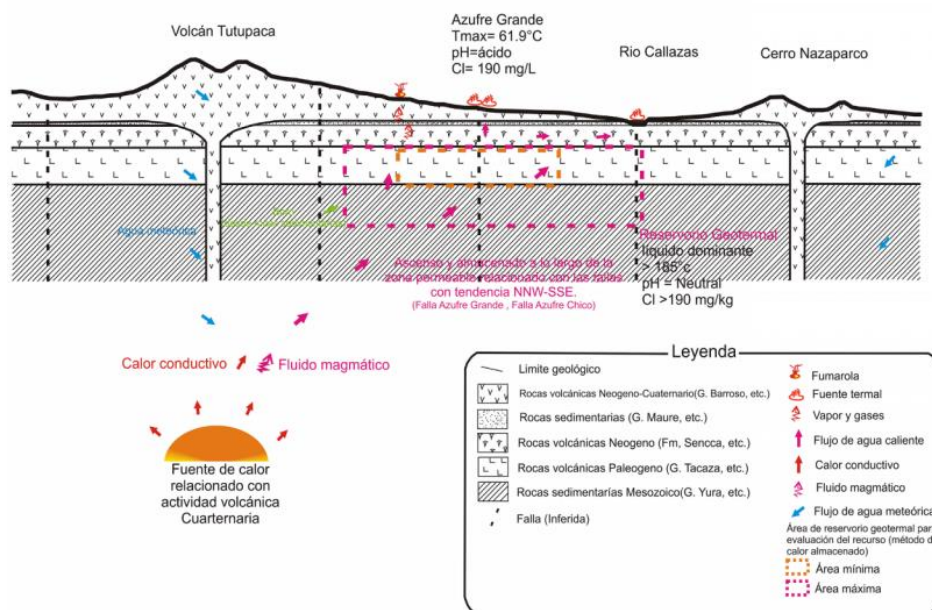

Source: Characterization and Evaluation of the potential of the Tacna region

According to Figure N°5. of the Tutupaca area, the best geothermal manifestation for the project is in the Callazas River area, since it is located in a maximum area of the geothermal reservoir, with a temperature of up to 185°C and with a flow of hot water. To determine the type of geothermal system capable of generating electrical energy, we must consider the characteristics of our chosen location. The three most used geothermal systems are:

- Dry steam system: It is considered the simplest, so it uses lower temperatures below 100 °C.
- Binary cycle system: This system is a bit more complex since the temperature is in the range of 100 to 150 ° C.
- Flash steam system: It is the most suitable for the use of energy with high energy values and its temperature ranges between 180 and 240 °C.

For the chosen area of Tutupaca, the appropriate geothermal system is flash steam because it meets the temperature conditions (180-240 °C) for the generation of electrical energy

3.1. GEOTHERMAL SYSTEM CONTROL

In the geothermal system, a well should be 1000 to 3000 meters deep and lined with special pipes and cement, which will join the cyclonic separator (water and steam separator). The steam that is extracted from the cyclonic division is transported by a network of pipes called haulage that reaches the collector that covers 6 pipes for each collector, from there it leads to a moisture separator whose function is to extract the remaining water that can transport the steam, then enters the turbine to turn the blades.

The water from the cyclone separator is led to a vaporization system that has the function of separating the steam from the hot water, then it is directed to a reinjection system, this steam is called low-priced steam, which is directed to a collector, to be taken to the turbine where both vapors move the blades to generate electricity. The turbine rotates around 3600 revolutions per minute, and the steam from the turbine turns the rotor producing electrical energy. This energy that comes out of the generator goes to a transformer where it is converted from 13,000 volts to 115,000 volts, which are directed to high-power lines of the electrical system, where they are transferred to the electrical station.

To finish the process, the steam after passing through the turbine is directed to a condenser where it is converted into the water using cylinders that inject water so that the steam condenses, and the steam converted into water is transferred to the cooling towers. where the temperature is lowered, part of the water is used for cooling equipment, and the rest is activated by a system of pipes so that they can return to the subsoil.

Figure XI. Scheme of geothermal system process

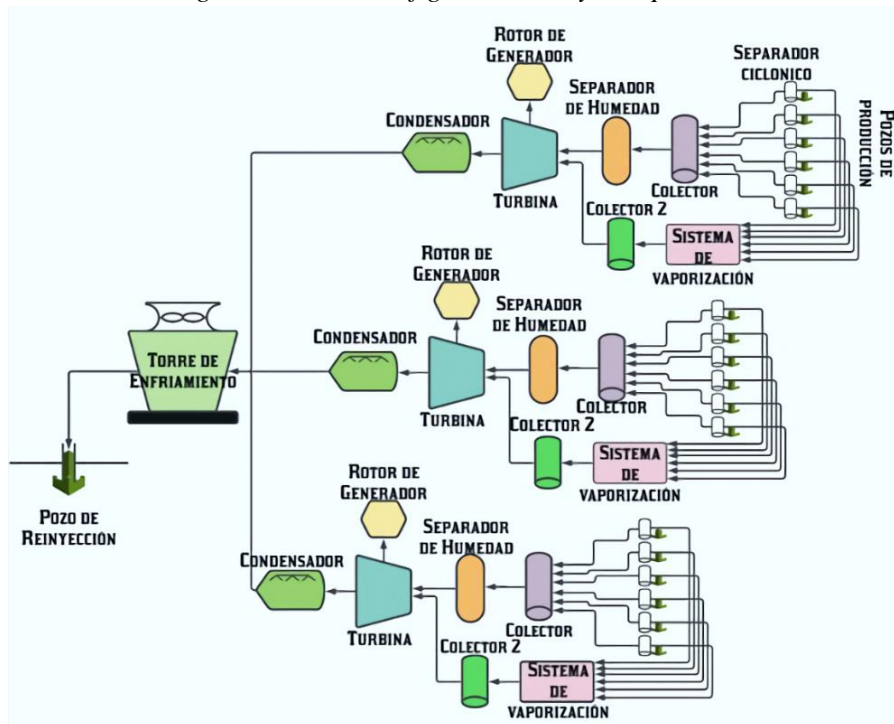

Source: Designed by the authors

The complete construction of the geothermal system has a total of ten parts, which are: the production well, cyclone separator, collectors, vaporization system, moisture separator, turbine, generation rotor, condenser, cooling tower, and reinjection. all these elements contribute to the process of the generation of electricity.

Figure VII. 2D geothermal system (plan view) of the Tutupaca area

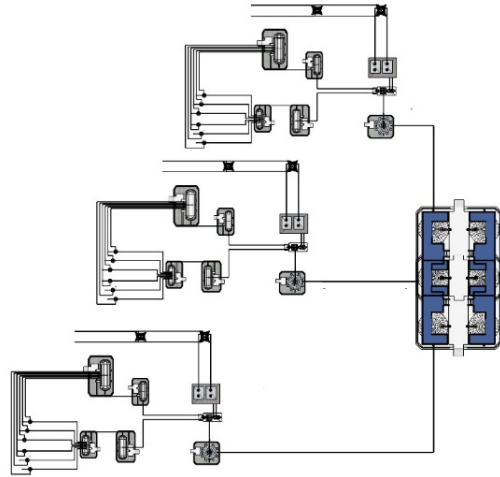

Source: Designed by the authors

Figure VIII. 2D geothermal system (side view) of the Tutupaca area

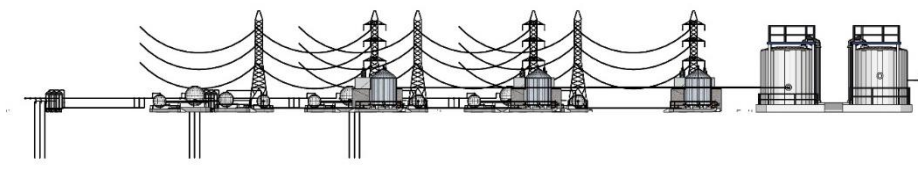

Source: Designed by the authors

This geothermal system, the flash cycle is the one that is suitable for the temperature of the Tutupaca area, this helps the system because it works with water vapor at high temperatures and does not need second materials or supplies to add, likewise the place of Tutupaca accommodates both system design and physical property characteristics.

Figure IX. Tutupaca Zone 3D Geothermal System



Source: Developed by the authors

Check: <https://youtu.be/DJtGHoZmYVc>

Figure X. 3D Geothermal System Tutupaca Zone



Source: Developed by the authors

Figure XI. Geothermal System 3D Tutupaca Zone

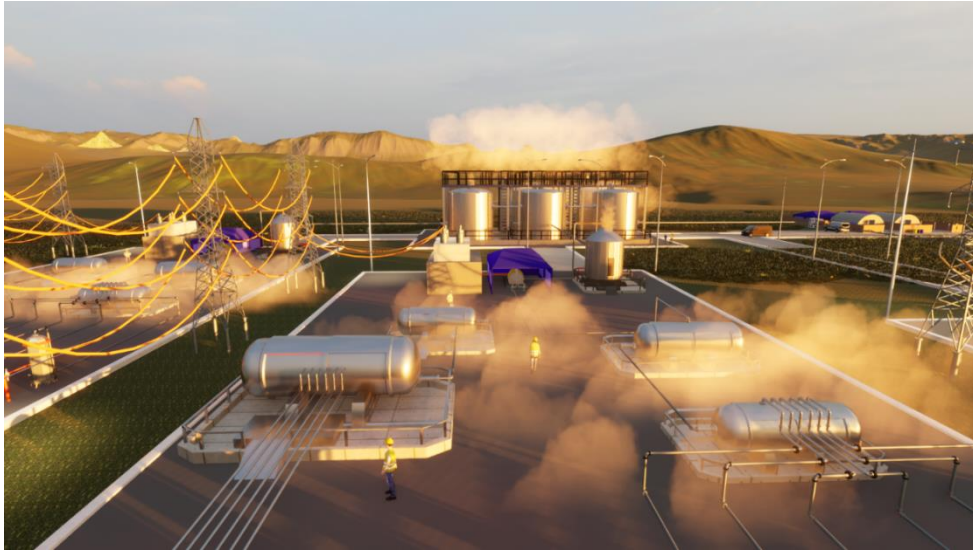

Source: Developed by the authors

Figure XII. Geothermal System 3D Tutupaca Zone

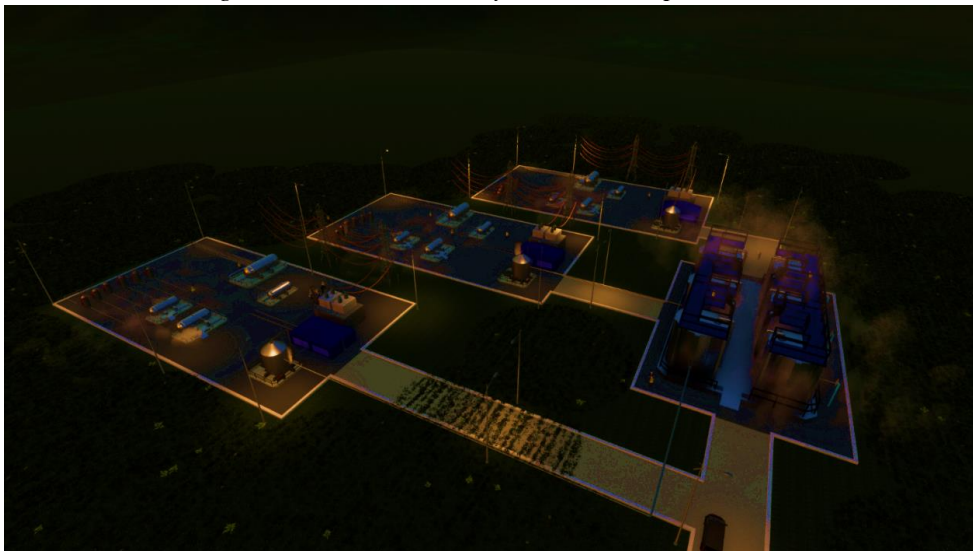

Source: Developed by the authors

Figure XIII. Geothermal System 3D Tutupaca Zone

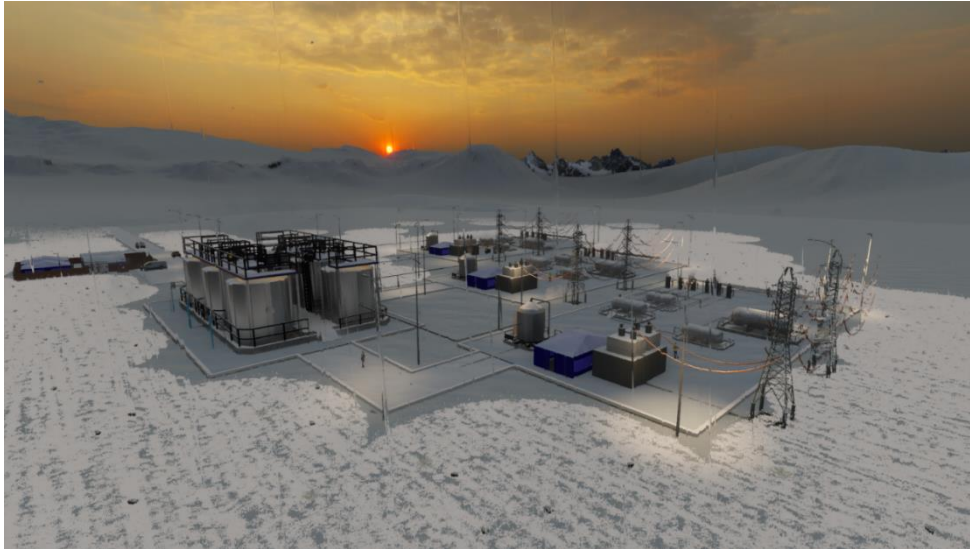

Source: Developed by the authors

4. Conclusion

4.1. Result Discussions

- With the detailed study of geothermal energy in Peru, it was possible to identify Tacna as the region with high geothermal and energy potential, which helped us recognize Tutupaca as the appropriate area for our geothermal system, which unlike the three remaining areas Tutupaca stands out for the characteristics that adapt to our project, mainly in temperature and energy potential.
- Our project is based on renewable energies, so it can be applied in other projects, since it is found in different parts of the world and is unlimited energy, it can be used complying with certain characteristics such as the area, temperature, accessibility of the place and type of geothermal plant; but if these characteristics are not considered, the application of this project cannot be carried out.
- According to the studies carried out by Laguna Monroy in 2012, our results were similar, since it shows that the Flash plant is one of the best systems for the use of geothermal energy, it is observed in the different countries that have already applied this system. Our research is an alternative solution to the energy demand in Peru since electricity will be obtained from a clean and inexhaustible source.

4.2. Conclusions

- With the studies carried out, the appropriate place to implement the geothermal system is in the Tutupaca area. Tacna Region, this place has a temperature above 150°C and with an energy potential of 105 MWe, these characteristics were necessary to identify the Flash plant as a suitable type capable of generating electricity.
- However, it has also been possible to find three areas such as Ancocallo, Borateras, and Caliente, all of which are within the Tacna region, where they met the temperature characteristics, but not with the energy potential to develop, which also opens up new possibilities. of simpler systems for its application in these places.
- The geothermal system design proposal must be suitable to the type of geothermal plant, having different parts and areas. The flash plant in the Tacna region will have eight main elements that will be connected to the pipe networks, grouped into six units, additionally, they can be connected at the end so that they can be injected into the subsoil.

5. Acknowledgments

Our gratitude is dedicated first to God and the Virgin Mary for giving us life, health, and the strength to face all the challenges to go this far. To the Continental University that gave us the training and the opportunity to perform professionally in the Environmental Engineering career. To our advisor Steve Camargo for guiding us and motivating us on this long journey to the completion of our project. To Enrique Vilcapoma Córdova and Danela Díaz Márquez for the great contribution, they gave us to carry out the investigation. To our families because they always supported and advised us in every decision of our lives.

References

- Acevedo, F. (2020). *Potencial geotérmico peruano equivale al 50% de la electricidad que producimos*. <https://www.rumbominero.com/peru/noticias/energia/potencial-geotermico-peruano-equivale-al-50-de-la-electricidad-que-producimos/>
- Adams, B. M., Ogland-Hand, J., Bielicki, J., Schädle, P., & Saar, M. (2021). Estimating the Geothermal Electricity Generation Potential of Sedimentary Basins Using genGEO (the generalizable GEOthermal techno-economic simulator). *ChemRxiv Preprint*, 21(1), 168–182.
- Bjork, I., Connors, C., Welch, T., Shaw, D., & Hewitt, W. (2014). *Promoviendo el Desarrollo de las Energías Renovables, Agencia de Estados Unidos para el Desarrollo Internacional (USAID)*. www.naruc.org/USAID/REHandbook
- Brender, N. (2018). *Master of Science in Energy and Environment FEASIBILITY STUDY FOR A MEDIUM-ENTHALPY GEOTHERMAL POWER PLANT IN*.
- Brunl, S. (2014). *La energía geotérmica*. Centro de Información Energetica. <https://publications.iadb.org/publications/spanish/document/Geotermia-Una-fuente-sostenible-de-energia.pdf>
- BULNES JIMÉNEZ, J. A. (2018). *Dimensionamiento Y Selección De Una Central Geotérmica Basada En El Ciclo Rankine Orgánico Ubicada En El Yacimiento Geotérmico Jesús María - Moquegua* [Tesis de título, Ingeniería Mecánica, Universidad nacional pedro ruiz gallo., Lambayeque, Perú]. <https://repositorio.unprg.edu.pe/handle/20.500.12893/2978>
- Dickson, M. H., & Fanelli, M. (2004). ¿Qué es la Energía Geotérmica? *International Geothermal Association, I*. <https://www.virtualpro.co/biblioteca/-que-es-la-energia-geotermica->
- Eduardo, C., Raipane, P., Referencia, M. D. E., & Estudio, D. E. L. (2016). “ANALISIS DE LA ENERGIA GEOTERMICA PARA SU IMPLEMENTACION EN EL AREA DE SALUD ESPECIFICAMENTE HOSPITALES Y CESFAM DE LA CIUDAD DE PUERTO MONTT - CALBUCO, REGION DE LOS LAGOS” *Tesina presentada como requisito para Optar al Grado de Licenciado en Adminis.*
- Fernández Menéndez, I., Vaz, M., Barbosa, V., Doutor, M., Manuel, R., Gomes, A., Doutora, P., Alves, M. A., Dionísio, R., Manuel, J., Velho, V., & Marques, B. (2020). *Building energy simulation to evaluate the use of geothermal energy for HVAC on a building of Academia Militar Mining and Geological Engineering Examination Committee*. July.
- Figuroa, F. Z. (2015). *Exploracion de energia geotermica y avances para su desarrollo en el peru*. Ministerio de Energía y Minas.
- García de la Noceda, C. (2008). Los recursos geotérmicos. *Enseñanza de Las Ciencias de La Tierra*, 16(3), 239–247. <https://es.scribd.com/document/524230631/164746-Text-de-l-article-216801-1-10-20100126-1>
- Gil, A. M. (2019). La Energía Geotérmica como fuente alternativa de abastecimiento para la demanda en Colombia [Tesis de título, Universidad Nacional Abierta y a Distancia UNAD., Medellín, Colombia]. In *Universidad Nacional Abierta y a Distancia Escuela de Ciencias Agrícolas, Pecuarias y del Medio Ambiente*.

<https://repository.unad.edu.co/handle/10596/26919>

- Gudni, A. (2004). SUSTAINABLE UTILIZATION OF GEOTHERMAL RESOURCES FOR 100 – 300 YEARS. *Geothermal Reservoir Engineering*, 1(175), 7–9.
- Heiken, G. H., Ander, M. E., & Shankland, T. J. (1983). HDR geothermal exploration. *Eos, Transactions American Geophysical Union*, 64(26), 435–436.
- INGEMMET. (2014). Caracterización y Evaluación del Potencial Geotérmico de la Región Moquegua. In *Serie C: Geodinámica e Ingeniería Geológica* (p. 20).
- INGEMMET. (2018). *GEO GPS PERÚ_ MAPA GEOTERMICO DEL PERÚ*.
- Laguna, I. (2002). Generación de energía y ambiente. *Gaceta Ecológica*, 65, 53–62.
- Llopis, G., & Rodrigo, V. (2008). *Guía de la Energía Geotérmica*. <https://www.fenercom.com/publicacion/guia-de-la-energia-geotermica-2008/>
- Lorente, C. (2020). *Impacto ambiental de la energía geotérmica en aplicaciones residenciales mediante análisis de ciclo de vida*. 105. file:///C:/Users/Usuario/Desktop/MAESTRÍA ENERGÍA RENOVABLE/3 MÓDULO INVESTIGACION/DANIEL ICAZA/PARA LATEAR Dialnet-ImpactoAmbientaldeLaEnergíaGeotermicaEnAplicacione-286856.pdf
- Munoz, F., Hickson, C., Cruz, V., Mendoza, M., Cardozo, M., De la Mata, U., Bona, P., Munoz Carmona, F., Geociencias, C., Geol, I., SAC Gerente, E., De la Mata ENEL Green Power Chile Países Andinos Ursula, U., & Bona Consultor Geotérmico, P. (2014). *Desarrollo geotérmico en el Perú*. <https://www.piensageotermia.com/wp-content/uploads/2014/10/Desarrollo-geotermico-en-Perú-opportunidades-conceptos-acciones-resultados-y-recomendaciones-OCT-1-2014.pdf>
- Navarra, G. de. (2018). *Estudio en profundidad sobre las posibilidades de aprovechamiento geotérmico en navarra e identificación de las zonas con mayor potencial*.
- Organismo Supervisor de la Inversión en Energía y Minería - OSINERGMIN. (2017). La Industria de la Energía Renovable en el Perú, 10 años de contribuciones a la mitigación del cambio climático. In *Demnada de energía limpia* (Vol. 1).
- OSINERGMIN. (2016). La industria de la electricidad en el Perú. In *Perú fuente de energía natural*. http://www.osinergmin.gob.pe/seccion/centro_documental/Institucional/Estudios_Economicos/Libros/Osinergmin-Industria-Electricidad-Peru-25anios.pdf
- Palacio-Villa, M. A., Blessent, D., López-Sánchez, J., & Moreno, D. (2020). Sistemas geotérmicos mejorados: revisión y análisis de casos de estudio. *Revista Boletín de Geología*, 42(1), 101–118.
- Paucara, V. C. (2012). *ENERGÍA GEOTÉRMICA*, INGEMMET, Perú, Boletín, Serie C: Geodinámica e Ingeniería Geológica, 58, 155 p.
- Paucara, V. C., Benavente, Y. V., & Aguilar, J. F. O. (2021). *Programa de Geotermia “Caracterización y evaluación del potencial geotérmico en la zona de Paucarani, región Tacna-Perú”*. INGEMMET, Boletín, Serie B: Geología Económica, 64, 272 p.

- Pous, J., & Jutglar, L. (2004). La utilización del recurso. *Energía Geotérmica*, 8. <http://books.google.es/books?id=4DcMwnKF4wwC&printsec=frontcover&dq=energ?a+geot?rmica&hl=es-419&sa=X&ei=Uy8SUBqzHcvHswa72YCICA&ved=0CC8Q6AEwAA#v=onepage&q=energ?a+geot?rmica&f=false>
- Pulido, J. L. (2017). *Estudio Y Diseño Preliminar De Una Planta De Generación Eléctrica a Partir De Energía Geotérmica En La Isla De Tenerife* [Tesis de título, Ingeniería mecánica., Universidad de la laguna., Tenerife, España]. https://riull.ull.es/xmlui/bitstream/handle/915/9511/Estudio_y_diseño_preliminar_de_una_planta_de_generacion_electrica_a_partir_de_energia_geotermica_en_la_isla_de_Tenerife.pdf?sequence=1
- República del Perú. (1997). Ley N° 26848: Ley Orgánica de Recursos Geotérmicos. In OSINERGMIN (Ed.), *Ley N° 26848: Ley Orgánica de Recursos Geotérmicos*. <https://cdn.www.gob.pe/uploads/document/file/892949/LEY-26848.pdf>
- Rivera Delgado, D. P., Díaz López, F. J., & Carrillo González, G. (2021). Transición energética, innovación y usos directos de energía geotérmica en México: un análisis de modelado temático. *Problemas Del Desarrollo. Revista Latinoamericana de Economía*, 52(206).
- Sanchez, J., Sanz, L., & Ocaña, L. (2011). Panorama actual de la utilización de la energía geotérmica en el mundo. In *Evaluación del potencial de energía geotérmica. Estudio Técnico PER 2011-2020* (pp. 10–15). <https://www.idae.es/index.php/publicaciones/evaluacion-del-potencial-de-energia-geotermica>
- Sera, A. S. (2015). Alternative of Electric Generation By Means of Renewable Energy Sources for Hotels in. *UNIVERSIDAD, CIENCIA y TECNOLOGÍA*, 19(74), 13–23.
- Tonus, B. P. de A., Lautenschläger, C. E. R., Visintin, A. F., Faro, V. P., & Tsuha, C. de H. C. (2022). Site characterization for a study on shallow geothermal energy exploitation in Southern Brazil. *Soils and Rocks*, 45(1), 1–13.
- Valenzuela Fuentes, F., & Valenzuela Fuentes, F. (2011). Energía Geotérmica y su Implementación en Chile. *Revista Interamericana de Ambiente y Turismo - RIAT*, 7(1), 1–9.
- Vega, L. A. (2013). Plan maestro para desarrollo de la geotermia en el Perú. In *Plan maestro para desarrollo de la geotermia en el Perú*. <https://docplayer.es/14311194-Plan-maestro-para-el-desarrollo-de-la-geotermia-en-el-peru.html>